



Section 9

Roll Groove Fittings

Edition 2

Specifications

About Roll Groove

Grooved piping system is reliable and faster to install than welding, threading or flanging. This results in the lowest possible installed cost. It can be adapted to suit standard pipe with cut grooves or standard and light wall pipe with rolled grooves.

Material Specifications	
Fittings	Ductile Iron conforming to ASTM A-536 Grade 65-45-12
Coatings	Hot Dipped Zinc galvanization
Bolts and Nuts	Black or Zinc Plated Oval Neck bolts and heavy hexagon nuts at ASTM A-183 with a minimum tensile strength of 110,00PSI
Gaskets	EPDM Elastomers with properties as designated by ASTM D-2000

Standard Roll Groove Specifications for Steel Pipe										
Nominal Pipe Size	Pipe Outside Diameter (mm) 'OD'			Gasket seat ±0.30 ±.770 (mm) 'A'	Groove width ± 0.30 ±.770 (mm) 'B'	Groove Diameter 'C'		Groove Depth 'D'	Min allow wall thickness (mm) 'T'	Max Flare Diameter (mm)
	Actual	Tolerance (+)	Tolerance (-)			mm	mm			
1	33.700	+0.381	-0.381	15.875	7.137	30.226	-0.381	1.600	1.651	34.5
1 1/4	42.400	+0.381	-0.381	15.875	7.137	38.989	-0.381	1.600	1.651	43.3
1 1/2	48.300	+0.381	-0.381	15.875	7.137	45.085	-0.381	1.600	1.651	49.4
2	60.300	+0.610	-0.610	15.875	8.738	57.150	-0.381	1.600	1.651	62.2
2 1/2	73.000	+0.737	-0.737	15.875	8.738	69.088	-0.457	1.981	2.108	75.2
3	88.900	+0.889	-0.737	15.875	8.738	84.938	-0.457	1.981	2.108	90.6
4	114.300	+1.143	-0.737	15.875	8.738	110.084	-0.508	2.108	2.108	116.2
5	141.300	+1.422	-0.737	15.875	8.738	137.033	-0.559	2.134	2.769	143.5
6	168.300	+1.600	-0.737	15.875	8.738	163.957	-0.559	2.159	2.769	170.7
8	219.100	+1.600	-0.737	19.050	11.913	214.401	-0.635	2.337	2.769	221.5

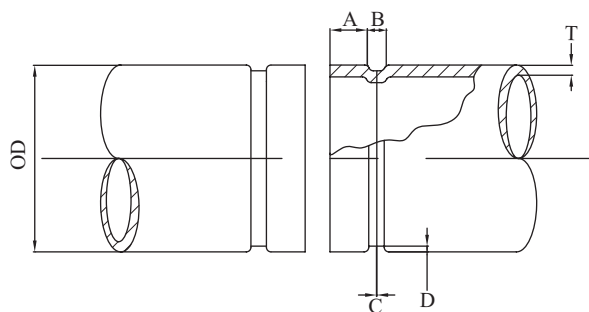

Specifications		
PRODUCT	WORKING PRESSURE	MAX WORKING TEMP
RIGID COUPLING	2500 kPa	100°C
90° ELBOW		
45° ELBOW		
EQUAL TEE		
REDUCING TEE		
CONCENTRIC REDUCER		
CAP	1600 kPa	
MECHANICAL TEE		

Roll Groove 90 Degree Elbow

Roll Groove 90 Degree Elbow				
AAP CODE		IMPERIAL SIZE	A	APPROX KG/PC
PAINTED	GALVANISED			
GE25		1	57	0.3
GE32	GE32G	1 1/4	70	0.5
GE40	GE40G	1 1/2	70	0.5
GE50	GE50G	2	70	0.9
GE65	GE65G	2 1/2	76	2.2
GE80	GE80G	3	85	2.2
GE94	GE94G	4	102	3.9
GE96	GE96G	6	130	8.3
GE98	GE98G	8	175	16
GEX25	GEX25G	10	229	-

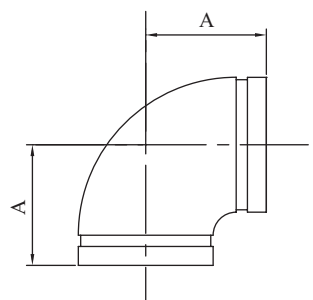
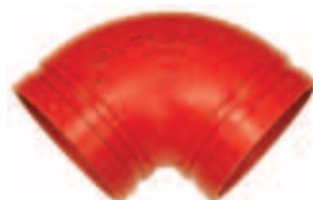

Roll Groove Rigid Coupling

Roll Groove Coupling							
AAP CODE		IMPERIAL SIZE	A	B	C	BOLT SIZE	APPROX KG/PC
PAINTED	GALVANISED						
GC25		1	33.7	97	45	2 x M10 x 40	0.45
GC32	GC32G	1 1/4	42.4	107.5	45		0.6
GC40	GC40G	1 1/2	69	114	45		0.65
GC50	GC50G	2	83.6	124	46	2 x M10 x 55	0.7
GC65	GC65G	2 1/2	98	140	46		0.95
GC80	GC80G	3	114	156	46	2 x M12 x 65	1.2
GC94	GC94G	4	142	189	50		1.5
GC96	GC96G	6	198	244	50	2 x M16 x 85	3.5
GC98	GC98G	8	260	322	58		4.95
GCX25	GCX25G	10	319	393	64	2 x M20 x 90	7.8

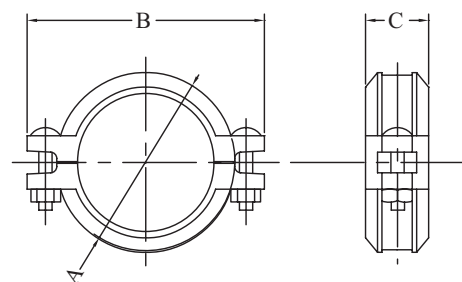

Roll Groove 45 Degree Elbow



Roll Groove 45 Degree Elbow				
AAP CODE		IMPERIAL SIZE	A	APPROX KG/PC
PAINTED	GALVANISED			
GEF50	GEF50G	2	55	0.8
GEF65	GEF65G	2 1/2	60	1
GEF80	GEF80G	3	65	1.4
GEF94	GEF94G	4	80	2.5
GEF96	GEF96G	6	95	5.4
GEF98	GEF98G	8	108	9.3

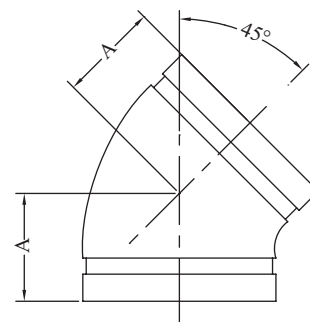

Roll Groove Equal Tee



Roll Groove Equal Tee				
AAP CODE		IMPERIAL SIZE	A	APPROX KG/PC
PAINTED	GALVANISED			
GT32	GT32G	1 1/4	70	0.7
GT40	GT40G	1 1/2	70	0.9
GT50	GT50G	2	70	1.3
GT65	GT65G	2 1/2	76	2.1
GT80	GT80G	3	85	2.8
GT94	GT94G	4	102	5.7
GT96	GT96G	6	130	12.4
GT98	GT98G	8	175	21.6
GTX25	GTX25G	10	215	-

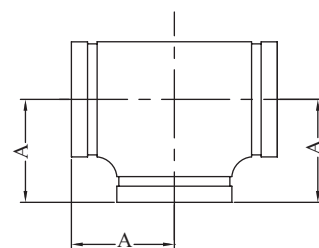

Roll Groove Concentric Reducer

Roll Groove Concentric Reducer				
AAP CODE		IMPERIAL SIZE	A	APPROX KG/PC
PAINTED	GALVANISED			
GCR5040		2 x 1 1/2	64	0.5
GCR6550	GCR6550G	2 1/2 x 2	90	0.6
GCR8050	GCR8050G	3 x 2	90	0.75
GCR8065	GCR8065G	3 x 2 1/2	90	0.7
GCR9450	GCR9450G	4 x 2	102	1.2
GCR9465	GCR9465G	4 x 2 1/2	102	1.2
GCR9480	GCR9480G	4 x 3	102	1.1
GCR9680	GCR9680G	6 x 3	102	1.95
GCR9694	GCR9694G	6 x 4	102	2.7
GCR9894		8 x 4	127	5.1
GCR9896		8 x 6	127	5.2

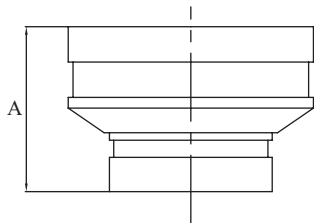

Roll Groove Cap

Roll Groove Cap				
AAP CODE		IMPERIAL SIZE	A	APPROX KG/PC
PAINTED	GALVANISED			
GCA50	GCA50G	2	24	0.3
GCA65	GCA65G	2 1/2	30	0.3
GCA80	GCA80G	3	30	0.5
GCA94	GCA94G	4	30	1.1
GCA96	GCA96G	6	30	2.3
GCA98	GCA98G	8	37	5



Roll Groove Flange Adaptor

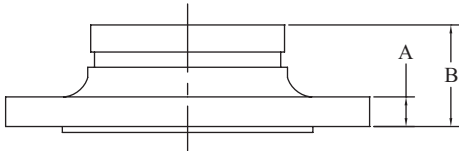

Roll Groove Flange Adaptor							
Flange Adaptor							
AAP CODE		IMPERIAL SIZE	A	B	HOLE DIAMETER	NO. HOLES	APPROX KG/PC
PAINTED	GALVANISED						
GFA94	GFA94G	4	11.5	65	18	4	3.5
GFA96	GFA96G	6	11.5	65	22	8	5

Roll Groove Galvanised Reducing Tee



Roll Groove Reducing Tee			
AAP CODE	IMPERIAL SIZE	A	APPROX KG/PC
GT8094G	3 X 3 X 4	115	2.76
GT9480G	4 x 3	95	5.2
GT9694G	6 x 4	130	10.9

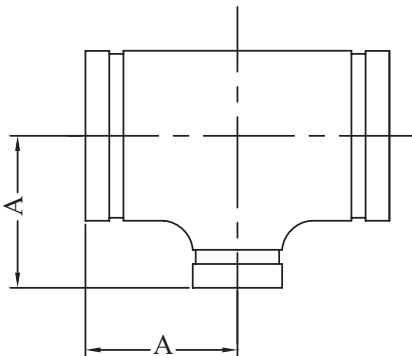

Roll Groove Mechanical Tees

Roll Groove Mechanical Tees							
AAP CODE		IMPERIAL SIZE	A	B	C	BOLT SIZE	APPROX KG/PC
MECH	BSP						
GTM8050	GTM8050B	3 x 2	152	66.5	98	2 x M10 x 55	2.4
GTM9450	GTM9450B	4 x 2	167	78	100	2 x M12 x 65	2.25
GTM9480	GTM9480B	4 x 3	167	82	129	2 x M12 x 65	3
GTM9680	GTM9680B	6 x 3	233	105.5	129	2 x M14 x 75	4.7

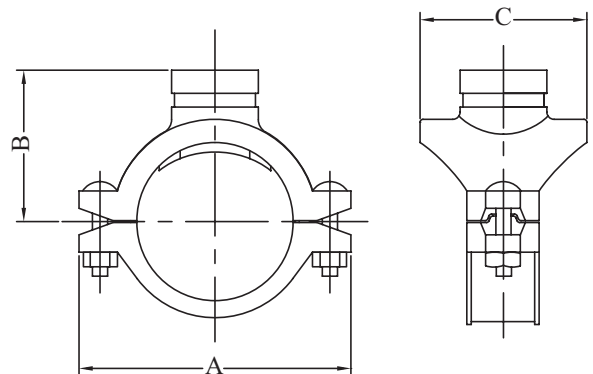

Roll Groove Lubricant

Roll Groove Lubricant	
Sundry Products	
AAP CODE	DESCRIPTION
GLUB500	Roll Groove Lubricant

BK Standard Pipe jointing lubricant has been specifically formulated to act as an effective lubricant in the jointing of pipe which requires the use of rubber gaskets. BK lubricant comes with Watermark approval to ATS 5200.014. LIC Number WMKA00103



Physical And Chemical Properties	
Boiling Point	130°C
Specific Gravity	1.05
pH Value	9 - 11
Solubility in Water	Complete

Ingredient Composition	
WATER	> 50%
OLEIC ACID SOAPONIFIED MIXTURES	> 20%
TALC	> 3%